

for low-voltage halogen lamps

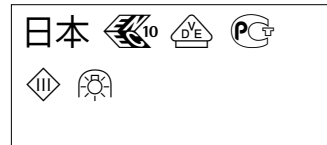
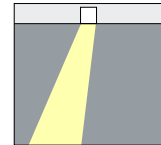
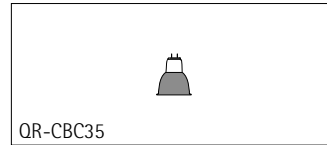
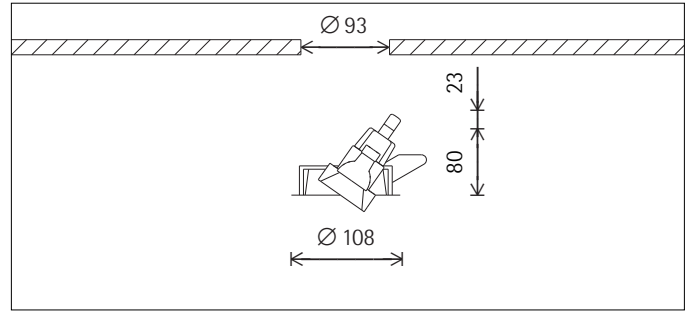
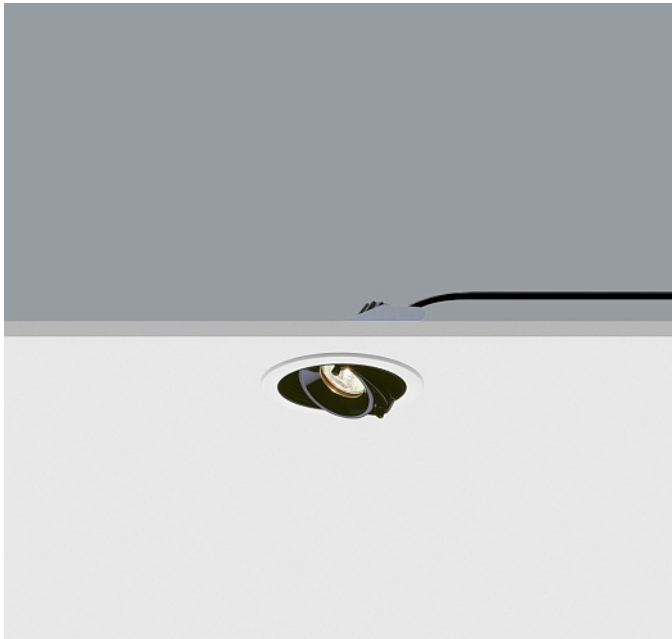

88100.000
 QR-CBC35 20W 12V GU4 10°
 QR-CBC35 20W 12V GU4 38°

Product description

Size 3
 Luminaire: cast aluminium, black powder-coated. Heat sink: black.
 Mounting ring: plastic, white (RAL9002), with multigroove baffle, cast aluminium, black powder-coated.
 Fixing springs for ceiling thickness max. 25mm. Cardanic suspension of the luminaire in the mounting ring. 0°-40° tilt. Pivots are to be locked.
 Cable, L 500mm.
 Anti-dazzle ring as lamp retainer: plastic, black.
 Transformer according to EN 61558 or EN 61347 to be ordered separately.
 Weight 0.25kg

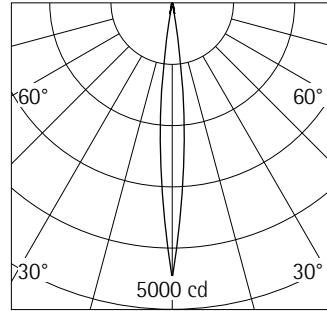

QR-CBC35 20W 12V GU4 10°

h(m)	E(lx)	D(m)
		10°
1	4500	0.17
2	1125	0.35
3	500	0.52
4	281	0.70
5	180	0.87

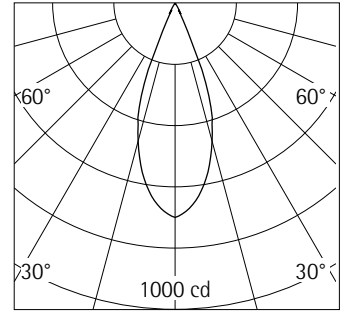

QR-CBC35 20W 12V GU4 38°

h(m)	E(lx)	D(m)
		39°
1	700	0.71
2	175	1.42
3	78	2.12
4	44	2.83
5	28	3.54

Planning data

Cleaning (a)	1				2				3			
	P	C	N	D	P	C	N	D	P	C	N	D
LMF	0.96	0.94	0.90	0.86	0.93	0.91	0.86	0.81	0.92	0.90	0.84	0.79
RSMF	0.96	0.92	0.87	0.81	0.96	0.92	0.87	0.81	0.96	0.92	0.87	0.81

Hours of operation (h)	1000	2000
LLMF	0.96	0.84
LSF	1	1

- MF LMFxRSMFxLLMFxLSF
- MF Maintainance Factor
- LMF Luminaire Maintenance Factor
- RSMF Room Surface Maintenance Factor
- LLMF Lamp Lumens Maintenance Factor
- LSF Lamp Survival Factor
- P Room pure
- C Room clean
- N Room normal
- D Room dirty

Accessories

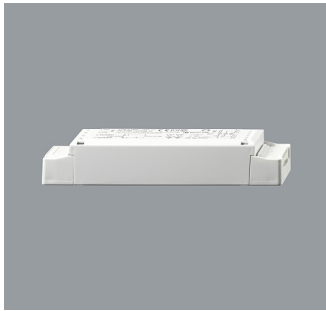

83817.000
DALI transformer EN 61347
230/240/12V, 50-60Hz. 20-105W at max 60°C ambient temperature.
Secondary voltage 11.8V.
Installation in ceiling voids, showcases, furniture.
Plastic housing. Primary and secondary cable clamps and terminal blocks.
Short-circuit protection: electronic cut-out, reconnect once short-circuit is cleared.

Overload and overheat protection: automatic load-sensing.
For interference suppression to VDE 0875, part 2, secondary conductor length 2m max.
For ceiling aperture \varnothing 80mm, recessed depth 90mm
Weight 0.18kg

SELV TS-115

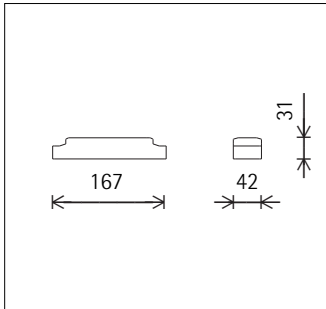

83829.000
DALI dimmer 1000W
for ohmic loads, conventional and electronic transformers.
Mounting on DIN rail.
Weight 0.18kg

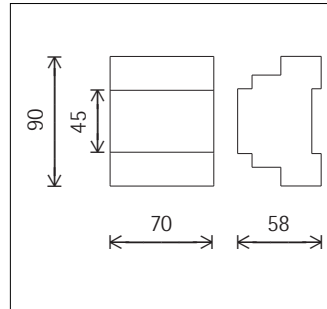

83831.000
Electronic transformer EN 61347
230/12V, 50-60Hz. 20-105W at max 50°C ambient temperature.
Secondary voltage 11.8V.
Installation in ceiling voids, showcases, furniture.
Plastic housing. Primary and secondary cable clamps and terminal blocks.
Short-circuit protection: electronic cut-out, reconnect once short-circuit is cleared.

Overload and overheat protection: automatic load-sensing.
Use dimmers for electronic transformers (trailing edge).

For interference suppression to VDE 0875, part 2, secondary conductor length 2m max.
For ceiling aperture \varnothing 80mm, recessed depth 70mm
Weight 0.19kg

SELV TS-115

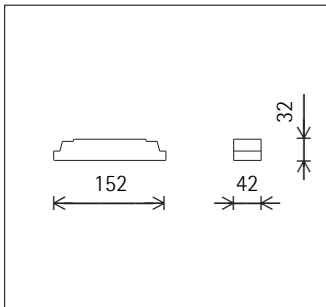

83816.000
DALI switch actuator, double, 16A
Two voltage-free contacts for switching ohmic, inductive and capacitive loads max 16A.
DALI interface with two independent addresses.
Mounting on DIN rail.
Weight 0.21kg

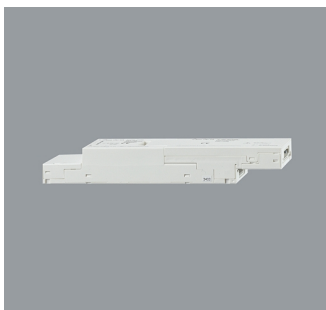
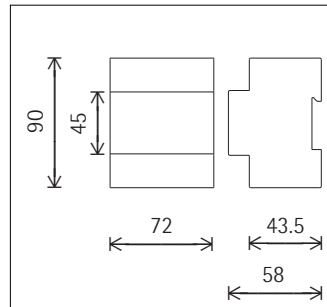

83833.000
Electronic transformer EN 61347
230/12V, 50Hz. 20-105W at max. 50°C ambient temperature, 1V-10V controllable.
Secondary voltage 11.7V.
Installation in ceiling voids, showcases, furniture.
Plastic housing. Primary and secondary cable clamps and terminal blocks.
Short-circuit protection: electronic cut-out, reconnect once short-circuit is cleared.

Overload and overheat protection: automatic load-sensing.
For interference suppression to VDE 0875, part 2, secondary conductor length 2m max.
For ceiling aperture \varnothing 80mm, recessed depth 125mm
Weight 0.20kg

SELV TS-115

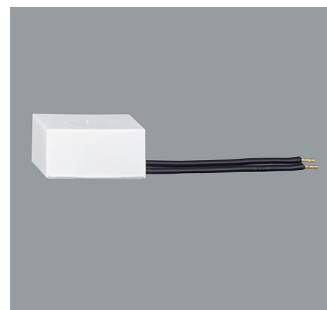
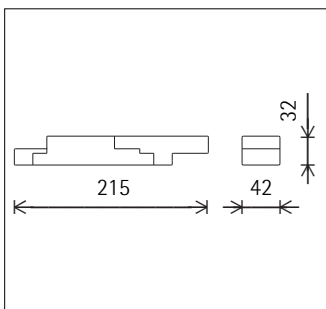

83819.000
Overvoltage protection device
for max. 10 electronic transformers.
L 45mm, B 25mm, H 22mm.
2x1,5mm², L 80mm.
Weight 0.05kg
Only in conjunction with:
83831.000
83833.000

Accessories



83579.000
 Concrete housing
 Metal, powder-coated.
 Recommended 0-8mm aggregate for
 the concrete.
 Weight 2.80kg

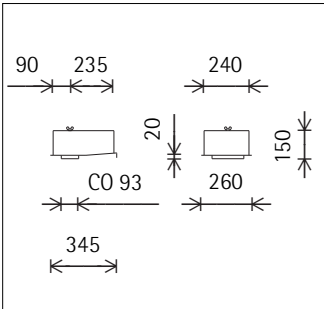

83956.000
 Plaster ring
 Metal, white.
 Height 20mm.



83980.000
 Cover ring
 Metal, white. For covering the gap
 where ceiling cut-outs are too big. In-
 ner and outer diameter to be specified
 when placing order.